

All Conveyors - Safety Section



Read manual before installing or using product. Failure to follow instructions and safety precautions in manual can result in death or serious injury. Keep manual in a safe location for future reference.



On safety decals, this symbol and the signal words Danger, Warning, Caution and Notice draw your attention to important instructions regarding safety.

They indicate potential hazards and levels of intensity.



RED - DANGER indicates an imminently hazardous situation which, if not avoided, will result in death or serious injury.



ORANGE - WARNING indicates a potentially hazardous situation which, if not avoided, could result in death or serious injury.



YELLOW - CAUTION indicates a potentially hazardous situation which, if not avoided, may result in minor or moderate injury.

NOTICE

BLUE - NOTICE alerts you to practices unrelated to personal injury, such as messages related to property damage.

IMPORTANT: To prevent serious injury or death to you or your family, it is essential that safety decals are clearly visible, in good condition, and applied to the appropriate equipment.

FOLLOW MANUAL & SAFETY DECAL MESSAGES

Carefully read this manual and all safety decals on your

equipment. Safety decals must be kept in good condition. Replace missing or damaged safety decals by contacting Sukup

Manufacturing Co. via mail at PO Box 677, Sheffield, Iowa USA, 50475; by phone at 641-892-4222; or by e-mail at info@sukup.com.

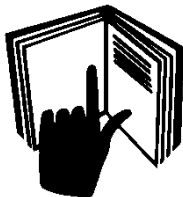

It is the responsibility of the owner/operator to know what specific requirements, precautions, and work hazards exist. It is also the responsibility of the owner/operator to inform anyone operating or working in the area of this equipment of hazards and safety precautions that need to be taken to avoid personal injury or death. Always keep children away from bins and vehicles with flowing grain.

Make no unauthorized modifications to machine. Modifications may endanger function and/or safety of unit. Keep unit in good working condition. Keep shields in place. Replace worn or missing shields free of charge by contacting Sukup Manufacturing Co.

GRAIN BIN SAFETY

Owners/operators are responsible for developing site-specific confined space entry procedures. OSHA's confined space entry procedures (29CFR 1910.146) can be found at www.osha.gov.

If you must enter bin for repair or maintenance:

- Use a safety harness, safety line and respirator
- Station another person outside of bin
- Avoid the center of the bin
- Wear appropriate personal protective equipment
- Keep clear of all augers and moving parts



DANGER: Never enter bin unless all power is locked out and another person is present.



Rotating augers can kill or dismember!

NEVER enter bin when augers are running!

When bin is nearly empty, sweep auger will travel at an increasingly fast speed. Keep away from sweep and sump augers to avoid entanglement.

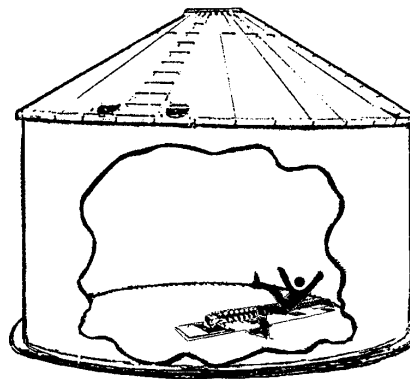

Failure to follow precautions above will result in death or serious injury.



DANGER: Flowing grain may trap and suffocate. If you enter a bin of flowing grain you can be completely submerged in grain in about 8 seconds.

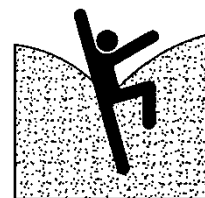

Failure to heed this warning will result in death or serious injury.

All Conveyors - Safety Section

To avoid electric shock or electrocution, all equipment must be properly wired and grounded according to electrical codes. Have unit wired by qualified electrician.



Have an electrician install a main power disconnect switch capable of being locked only in OFF position. Mark disconnect clearly as to equipment it operates. Always lock out main power disconnect switch whenever equipment is not in use.

Service Disconnect

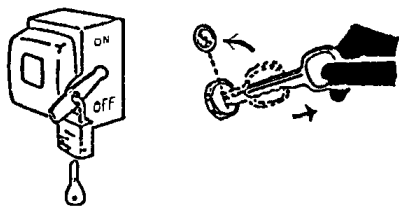

WARNING: When servicing equipment, never enter bin unless all power is locked out and another person is present. Always LOCK OUT all power and always check with voltage meter before servicing.

Failure to do so could result in death or serious injury.

Owners/operators are responsible for developing site-specific Lockout/Tagout procedures based on equipment at their work site. See OSHA's typical minimal lockout procedures (29CFR 1910.147 App A) at www.osha.gov.

WARNING: KEEP CLEAR OF ALL MOVING PARTS.

Keep people (ESPECIALLY YOUTH) away from equipment, particularly during operation.

Keep away from all moving parts. Keep all shields in place. **SHUT OFF AND LOCK OUT** all power before servicing.



Failure to follow precautions above could result in death or serious injury.

WARNING: Metal is slippery when wet. To avoid falls, never carry items if climbing on bin. Maintain secure hand and foothold if climbing on bin. Failure to do so could result in death or serious injury.

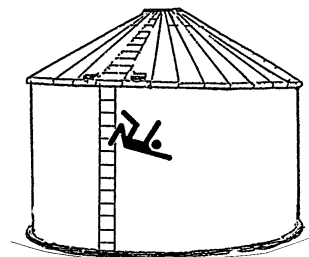

CAUTION: Metal edges are sharp. To avoid injury, wear protective clothing and handle equipment and parts with care.

Failure to do so may result in minor or moderate injury.

PERSONAL PROTECTIVE EQUIPMENT



Owners/Operators are responsible for developing site-specific personal protective equipment standards. OSHA's personal protective equipment standards (29CFR 1910.132) can be found at www.osha.gov.

EMERGENCIES – KNOW WHAT TO DO

Have emergency numbers and written directions to work site readily available in case of emergency. An area for emergency phone numbers to be recorded is provided below and at end of this manual.

Ambulance • Fire • Police: 9-1-1

Bin rescue team: _____

Emergency medical squad: _____

Address of work site: _____

Directions to work site: _____

All Conveyors - Safety Section

Do not enter a grain bin if grain has bridged or stopped flowing normally. Grain can collapse without warning and can trap, bury and cause suffocation. See Fig. 1.

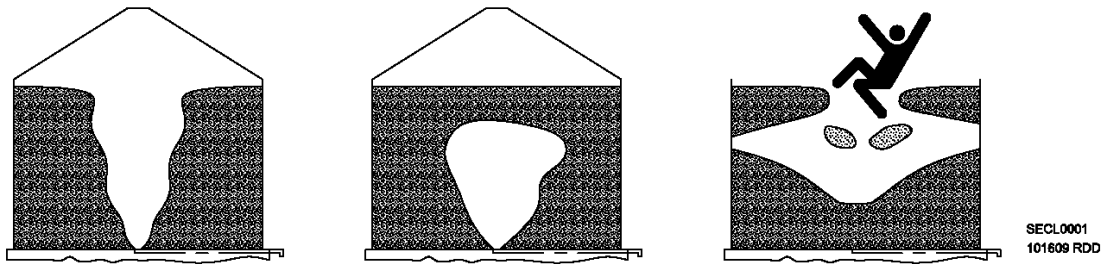

Fig. 1 – Obstructed-flow, bridged grain, collapsed bridge of grain in bin

Basic safety rules

1. Be certain that all covers, grates and guards are in place and securely fastened.
2. Never step or walk on conveyor covers, grates or guards.
3. Lock out all power before removing covers, grates or guards. Before working on any part of conveyor, secure all chains and belts to prevent movement.
4. Do not modify or redesign chain loop conveyor without first obtaining written approval from Sukup Manufacturing Co. Unauthorized modifications to components may impair function and/or safety and affect machine life.



FOLLOW A PROPER LOCKOUT PROCEDURE

This suggested procedure must be performed **EVERY TIME** conveyor is to be worked on. Following these steps will assist in preventing accidents.

Each worker must have his/her own lock and the only key to that lock.

Make sure conveyor is not operating before turning off power.

Notify all affected employees that conveyor will be locked out for service.

Authorized employee shall refer to the facility procedure referencing the power source for the conveyor.

Shut down conveyor in a normal manner.

All energy sources that could activate conveyor must be deactivated.

Each person who will be working on conveyor must put a lock on each energy source that could provide any power to conveyor.

Confirm that power has been deactivated by trying to re-start conveyor.

Turn all controls for conveyor to “Off” position.

NO ONE is to return power to conveyor until all work on it has been completed and all locks have been removed.

Facility management needs to proactively train employees to ensure use of proper lockout procedures while working on conveyor. Management also needs to inspect unit for any covers or guards not in their proper place. It is everyone’s responsibility to report any missing grates, guards, equipment failures or failures of others to lock out.

SAFETY QUESTIONS OR CONCERNS

Please contact Sukup Manufacturing Co. with any specific safety concerns about chain loop conveyor or its use.

Electrical Wire Clearances

Your local electric utility may be able to provide assistance in planning a safe environment for working around grain bins. State codes may vary regarding specific clearances for electrical lines around grain bins. Be certain your local electric utility is in accordance with your state's regulations. **To prevent overhead safety issues, bury electrical lines.**

American National Standards Institute (ANSI) provides clearance envelopes, shown in Fig. 2, for grain bins filled by permanently installed augers, conveyors or elevators in (ANSI) C2 2007 "National Electrical Safety Code," Rule 234, page 120.

NOTE: An electric utility may refuse to provide electrical service to any grain bin built near an existing electric line that does not provide clearance required by ANSI and the National Electrical Safety Code.

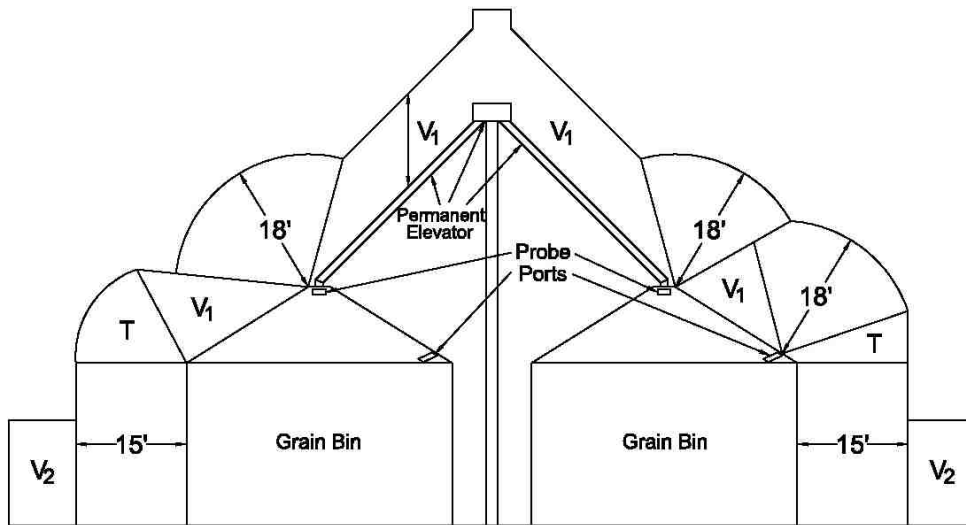

V_1 = Vertical clearance above a building required by Rule 234C (Table 234-1)

V_2 = Vertical clearance above land required by Rule 232

T = Transition clearance

Fig. 2 – Electrical wire clearances

Chain Loop Conveyor

Chain Loop Conveyor Safety Decals

It is essential that safety decals below be mounted on chain loop conveyor to warn and remind of potential hazards. Decals are factory-mounted, but may need to be replaced if they become damaged or unreadable. Order replacement safety decals or shields free of charge by contacting Sukup Manufacturing Co. by mail at PO Box 677, Sheffield, Iowa USA 50475; by phone at 641-892-4222; or by e-mail at info@sukup.com. Please specify decal number. Use Fig. 3 to determine location of decals if replacement is necessary.

1. **Decal L0113 - WARNING:** Falling from heights may cause serious injury or death.



2. **Decal L01132 - WARNING:** Do NOT walk or stand on covers or guards!



3. **Decal L0114 - WARNING:** Exposed buckets or flights may cause serious injury or death.



4. **Decal L0271 - DANGER:** Shield missing. Do not operate!



5. **Decal L0281 - WARNING:** To avoid serious injury or death.



6. **Decal L0284 - WARNING:** Keep away from all moving parts.



Chain Loop Conveyor

Chain Loop Safety Decal Placement

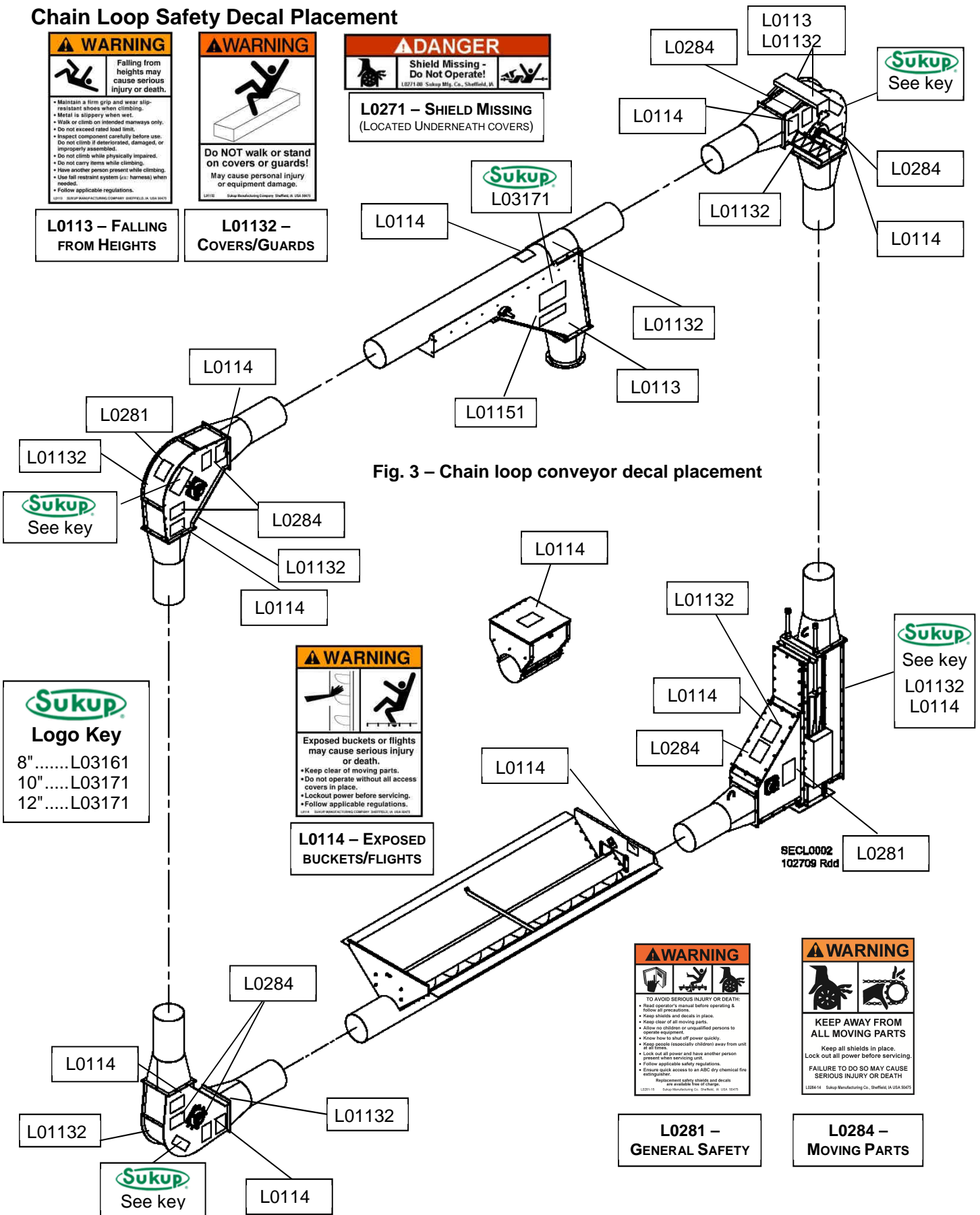

Operation of Chain Loop Conveyor

Prior to start-up, check the following:

1. Power is shut off and locked out while equipment is being inspected.
2. All bolts, setscrews and other fasteners have been tightened.
3. All guards and safety decals are in place.
4. Reducer(s) is/are filled with oil.
5. Chain is free to move, properly tensioned, and is not twisted.
6. Corner sprockets are aligned with chain and centered in housings.
7. Discharge gates are fully closed.
8. All material not related to operation of conveyor is removed.

Before running loop conveyor at full capacity, it should be run in a partial or no-load condition to polish tube walls. This should be done during initial break-in period as well as after system has been idle for an extended period of time. During startup, operator should inspect for any unusual vibrations or noises.

NOTE: A final tensioning of chain must be done while conveyor is loaded. Avoid tightening one take-up screw more than the other by noting degrees of turn and frequently switching between the two screws. This method should be used every time tension is adjusted.

A. Basic Procedure for Filling Bins

1. Open discharge gate above destination bin.
2. Unless grains must not be mixed, open discharge gate above a downstream bin from destination bin so downstream bin receives any overflow.
3. Start chain loop drive motor(s). Station a person at control box to monitor amp meter(s) of drive motor(s).
4. Allow grain to flow into inlet hopper. Open flow control by adjusting chains on hopper a small amount at a time. See Fig. 65. Ensure grain has enough time to travel throughout system before making changes. Adjust grain flow so tube is consistently about 3/4 full of grain. Also, make sure electric drive motor(s) amperage does not exceed rated amperage draw as shown on motor nameplate(s). Be careful not to overload conveyor.

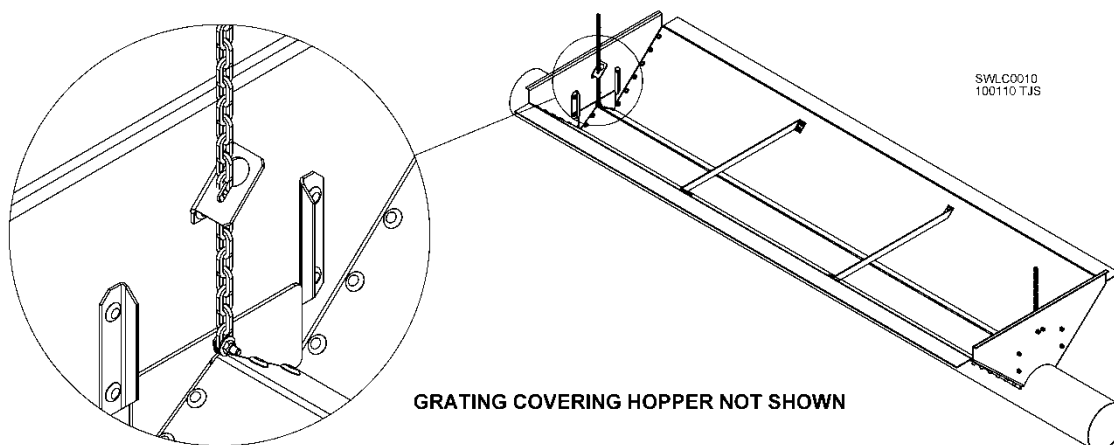

Fig. 65 – Using chain to adjust flow from hopper

Chain Loop Conveyor Final Check and Operation

Operation (continued)

- a. On both ends of hopper, keep the same number of chain links between chain bracket and hopper cover to prevent hopper cover from binding.
- b. View ports can be added “downstream” of grain inlets to check grain flow. See Fig. 66.

IMPORTANT - It is critical to make small, slow changes when adjusting grain flow rates. If rate is increased too quickly, by the time an overload condition is noticed, it may be too late to take corrective action to prevent a machine stoppage.

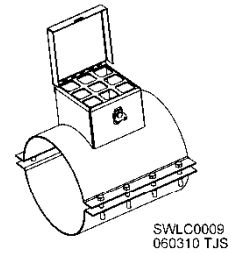

Fig. 66 – View port

5. Let chain loop run until system is empty. Starting system under load stresses components and leads to premature wear, maintenance issues, and shortened machinery life.
6. Close discharge gates and dump hopper flow control when filling is complete.
7. Shut down drive motor(s).

B. Basic Procedure for Unloading Bins

1. Open discharge gate above truck load/unload area.
2. Open discharge gate above bin being unloaded.
3. Start chain loop drive motor(s). Station a person at control box to monitor amp meter(s) of drive motor(s).
4. Open bin sumps or other inlets to allow grain into chain loop conveyor.
 - a. Make sure tube is consistently about 3/4 full of grain.
 - b. Also, make sure drive motor amperage draw does not exceed motor's rating.
5. Before transport vehicle is full, reduce grain flow into chain loop conveyor.
6. Close discharge gate above truck load/unload area when transport vehicle is full. **Do not shut off chain loop conveyor at this time.**
 - a. Grain will recirculate back into unload bin. Drive motor amperage will increase due to extra distance grain is traveling. It is important to gain experience with system to know how much drive motor amperage will increase when grain travels increased distance back to bin being unloaded.
7. Close inlets to chain loop conveyor.
8. Shut off chain loop drive motor(s) when chain loop conveyor is clear of material.

IMPORTANT: If using loop system for grains that should not be combined, such as genetically modified and organic, entire loop system must be cleaned before switching commodities. Fig. 67 shows where grain commonly remains in upper tube after usage.

Choice of cleaning method is up to operator.

DISCLAIMER: Sukup Manufacturing Co. is not responsible for cross-contamination of grain or for damage to grain or equipment while cleaning.



WARNING: Lock out power to conveyor if removing back covers of lower corner(s) for cleaning. Contact with moving chain and/or paddles could cause death or serious injury.

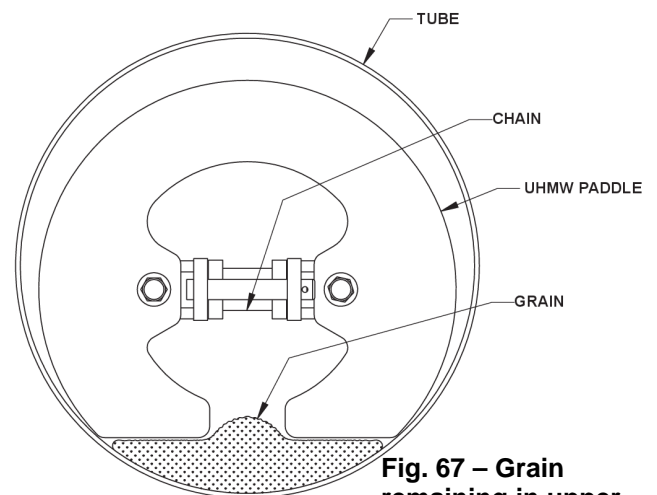

Fig. 67 – Grain remaining in upper tube of loop

SWLC0047
02/18/2015 DDV

Double Run Conveyor

Double Run Conveyor Safety Decals

It is essential that the following safety decals be mounted on double run conveyor to warn and remind of potential hazards. Decals are factory-mounted, but may need to be replaced if damaged or worn. Order replacement safety decals or shields free of charge by contacting Sukup Manufacturing Co. by mail at PO Box 677, Sheffield, Iowa, USA 50475; by phone at 641-892-4222; or by e-mail at info@sukup.com. Please specify decal identification number. See decal placement drawing on Page 10 for locations of decals.

1. **Decal L0281- WARNING:** To avoid serious injury or death.



2. **Decal L0284 – WARNING:** Keep away from all moving parts.



3. **Decal L0271 – DANGER:** Shield missing. Do not operate!



4. **Decal L0114 – WARNING:** Exposed buckets or flights may cause serious injury or death.



5. **Decal L02612 – WARNING:** Flying material can cause serious injury!



6. **Decal L01132 – WARNING:** Do NOT walk or stand on covers or guards!



7. **Decal L0113 – WARNING:** Falling from heights may cause serious injury or death.



Double Run Conveyor

Double Run Conveyor Safety Decal Placement

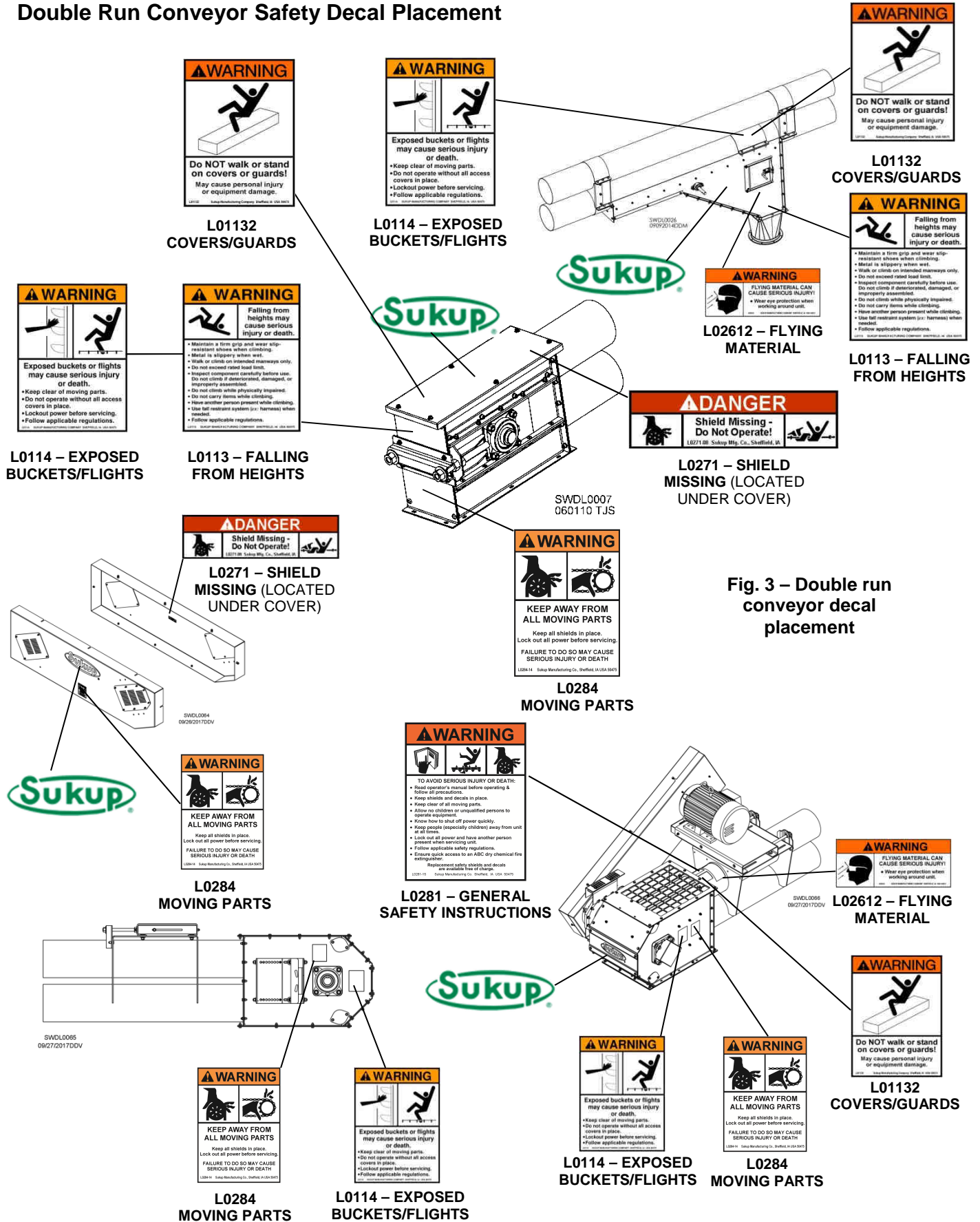

Fig. 3 – Double run conveyor decal placement

Double Run Final Check & Operation

Double Run Final Check

Prior to start-up, check the following:

1. All electrical power is disconnected and locked out.
2. All fasteners on conveyor have been tightened.
3. Construction tools, debris and other material not related to conveying process are removed.
4. Chain is not twisted, moves freely and is tensioned properly, with paddles in correct direction.
5. Chain is centered when it exits and enters tube sections.
6. Sprockets are aligned with chain.
7. Setscrews in drive pulleys, head and tail sprockets, shaft bearings and gear reducer are all tight.
8. Reducer is filled with oil and drive belts have been properly tightened.
9. All guards and safety decals are in place.
10. Restore power to conveyor.

Operation

Before running conveyor at full capacity, it should be run in a partial load condition to polish tube walls. This should be done during initial break-in period as well as after system has been idle for an extended period of time. During start-up, operator should be alert for any unusual vibrations or noises.

NOTE: A final tensioning of chain must be done while conveyor is loaded. Avoid tightening one take-up screw more than the other by noting degrees of turn and frequently switching between the two screws. This method should be used every time tension is adjusted.

IMPORTANT: Running conveyor at full capacity before tubing is polished and starting conveyor under load cause excessive stress on components, increased wear, and premature failure. Stalling will most likely occur in these situations. **Never “flood-feed” conveyor.**

A basic sequence for using Sukup Double Run Conveyor is as follows:

1. Ensure grain has a place to flow to during operation by opening bin lid, discharge, etc.
2. Start Double Run drive motor. Station a person at control box to monitor amp gauge of drive motor.
3. Check conveyor for vibration and unusual noise.
4. Allow only a small amount of grain at a time to flow into inlet hopper to make sure amperage does not exceed capability of motor. **Be careful not to overload conveyor.**
5. Let conveyor run until system is empty.
6. Shut down drive motor.

Start-Up after Emergency Shutdown

1. Lock out power source.
2. Remove as much grain as possible from conveyor.
3. Reattach any guards and other items removed for clearing.
4. Reconnect power source and start conveyor as carefully as possible.

Drag Conveyor

Drag Conveyor Safety Decals

It is essential that safety decals below be mounted on drag conveyor to warn and remind of potential hazards. Decals are factory-mounted, but may need to be replaced if damaged or worn. Order replacement safety decals or shields free of charge by contacting Sukup Manufacturing Co. by mail at PO Box 677, Sheffield, Iowa 50475; by phone at 641-892-4222; or by e-mail at info@sukup.com. Please specify decal identification number. See Fig. 3 for locations of decals.

1. **Decal L0113 – WARNING:** Falling from heights may cause serious injury or death.



2. **Decal L01132 – WARNING:** Do NOT walk or stand on covers or guards!



3. **Decal L0114 - WARNING:** Exposed buckets or flights may cause serious injury or death.



4. **Decal L0271 – DANGER:** Shield missing, do not operate!



5. **Decal L0281 - WARNING:** To avoid serious injury or death:



6. **Decal L0284 - WARNING:** Keep away from all moving parts



Drag Conveyor

Safety Decal Placement

Check that all safety decals are in place as shown in Fig. 3 and are legible when conveyor is installed.

If decal replacement is necessary, use locations below. Make sure location for decal is free from grease, oil and dirt. Remove backing from decal and place in proper position.

IMPORTANT: If suggested location is not clearly visible, place safety decal in a more suitable area. Never cover up an existing safety decal.

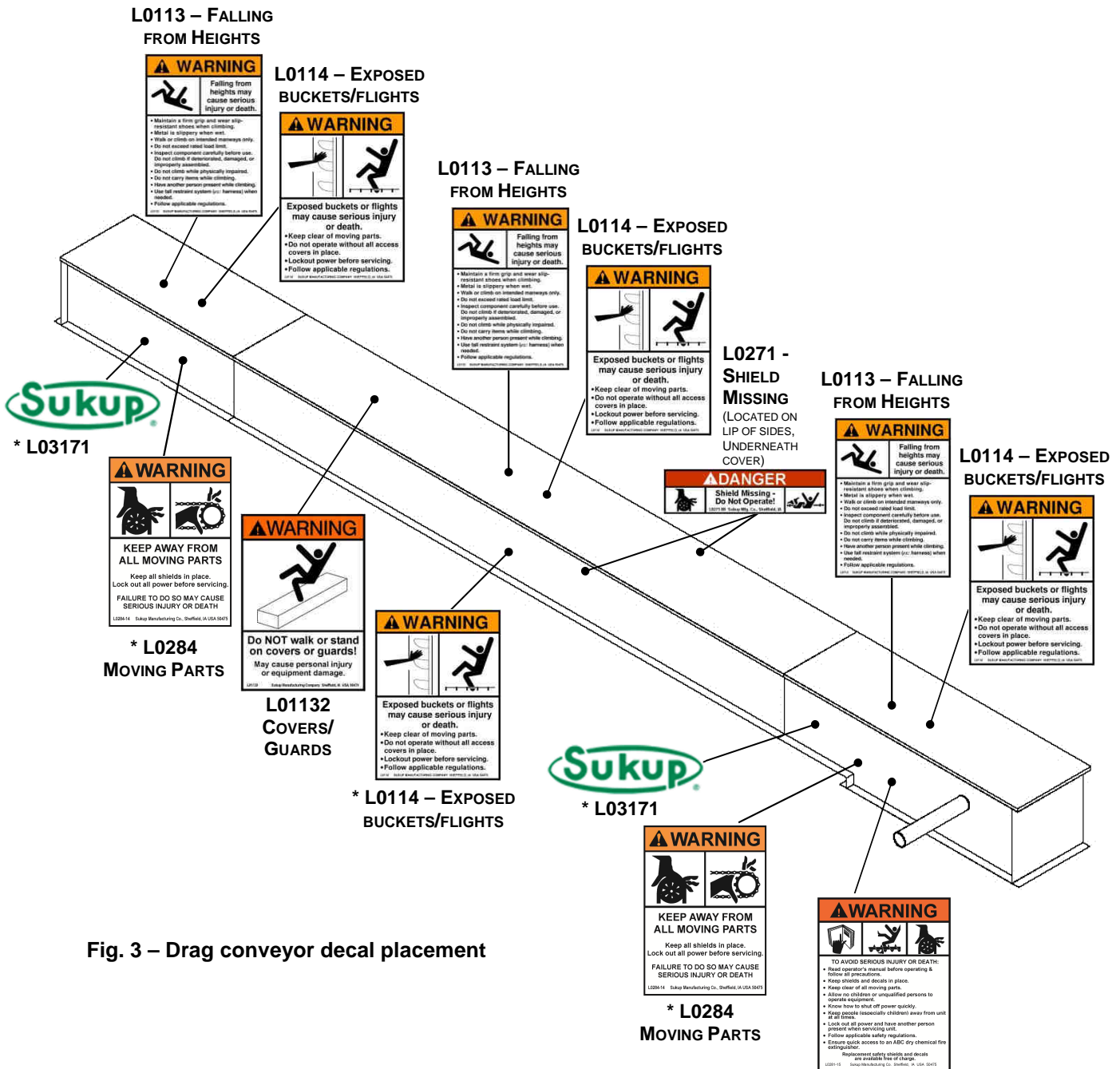

Fig. 3 – Drag conveyor decal placement

* Used on both sides of conveyor

Drag Conveyor Final Check and Operation

Final Check

Before operating conveyor, check all areas for SAFETY and machine damage that could have happened during construction. Follow step-by-step procedure below for initial start-up and operation, paying close attention to caution statements.

1. Disconnect and LOCK OUT all electrical power.
2. Check entire conveyor for loose bolts, construction tools, construction debris and/or any other material not related to conveying material, and remove before start-up.
3. Check for proper chain and paddle direction. Check chain tension and adjust if necessary.
4. Check to see that all appropriate decals are present on conveyor.
5. Check to make sure conveyor has been properly aligned.
6. Check all setscrews in drive pulleys, head and tail sprockets, shaft bearings and gear reducer.
7. Check lubrication of gear reducer. **NOTE:** Reducer is shipped without oil. See Pages 63-65.
8. Operate conveyor empty for a period of time, keeping personnel away from moving parts.
9. Disconnect and lock out all electrical power.
10. Make any needed adjustments.
11. Check all discharge gates to ensure they open and close properly.
12. Make sure all covers and guards are re-installed following any adjustments.

Conveyor Operation

Since conveyor has been previously operated without material, it may now be tested under load. It is suggested that flow systems be checked next. Allow only a small amount of grain to enter conveyor. Check that material can flow through system connections, valves, distributors, etc. Once all flow paths have been checked, conveyor may be loaded to capacity.

NOTICE: If bin is equipped with a sidedraw, do not use at same time sumps are being used to unload grain.

NOTICE: If conveyor is used for bin unloading, sumps must be control-fed using rack & pinion opener. Over-filling conveyor via sumps can cause damage to conveyor paddles, chains and other components.

INSPECT CONVEYOR AFTER FIRST 8 TO 10 HOURS OF OPERATION. This should include:

- Inspect motor drive for loose pulleys, sprockets, belts, chains, paddles, etc.
- Check for oil leakage or overheating of gear reducer.
- Check head and tail sprocket hub bolts and setscrews.
- Check chain for tension.

Hy-Flight Conveyor

Hy-Flight Conveyor Safety Decals

It is essential that safety decals below be mounted on Hy-Flight Conveyor to warn and remind of potential hazards. Decals are factory-mounted, but may need to be replaced if damaged or worn. Order replacement safety decals or shields free of charge by contacting Sukup Manufacturing Co. by mail at PO Box 677, Sheffield, Iowa USA 50475-0677; by phone at 641-892-4222; or by e-mail at info@sukup.com. Please specify decal identification number. See Fig. 2 for locations of decals.

1. **Decal L0113 – WARNING:** Falling from heights may cause serious injury or death.



2. **Decal L01132 – WARNING:** Do NOT walk or stand on covers or guards!



3. **Decal L0114 - WARNING:** Exposed buckets or flights may cause serious injury or death.



4. **Decal L0271 – DANGER:** Shield missing, do not operate!



5. **Decal L0281 - WARNING:** To avoid serious injury or death:



6. **Decal L0284 - WARNING:** Keep away from all moving parts



Hy-Flight Conveyor

Hy-Flight Conveyor Safety Decal Placement

Check that all safety decals are in place as shown in Fig. 2 and are legible when conveyor is installed.

If decal replacement is necessary, use locations below. Make sure location for decal is free from grease, oil and dirt. Remove backing from decal and place in proper position.

IMPORTANT: If suggested location is not clearly visible, place safety decal in a more suitable area. Never cover up an existing safety decal.

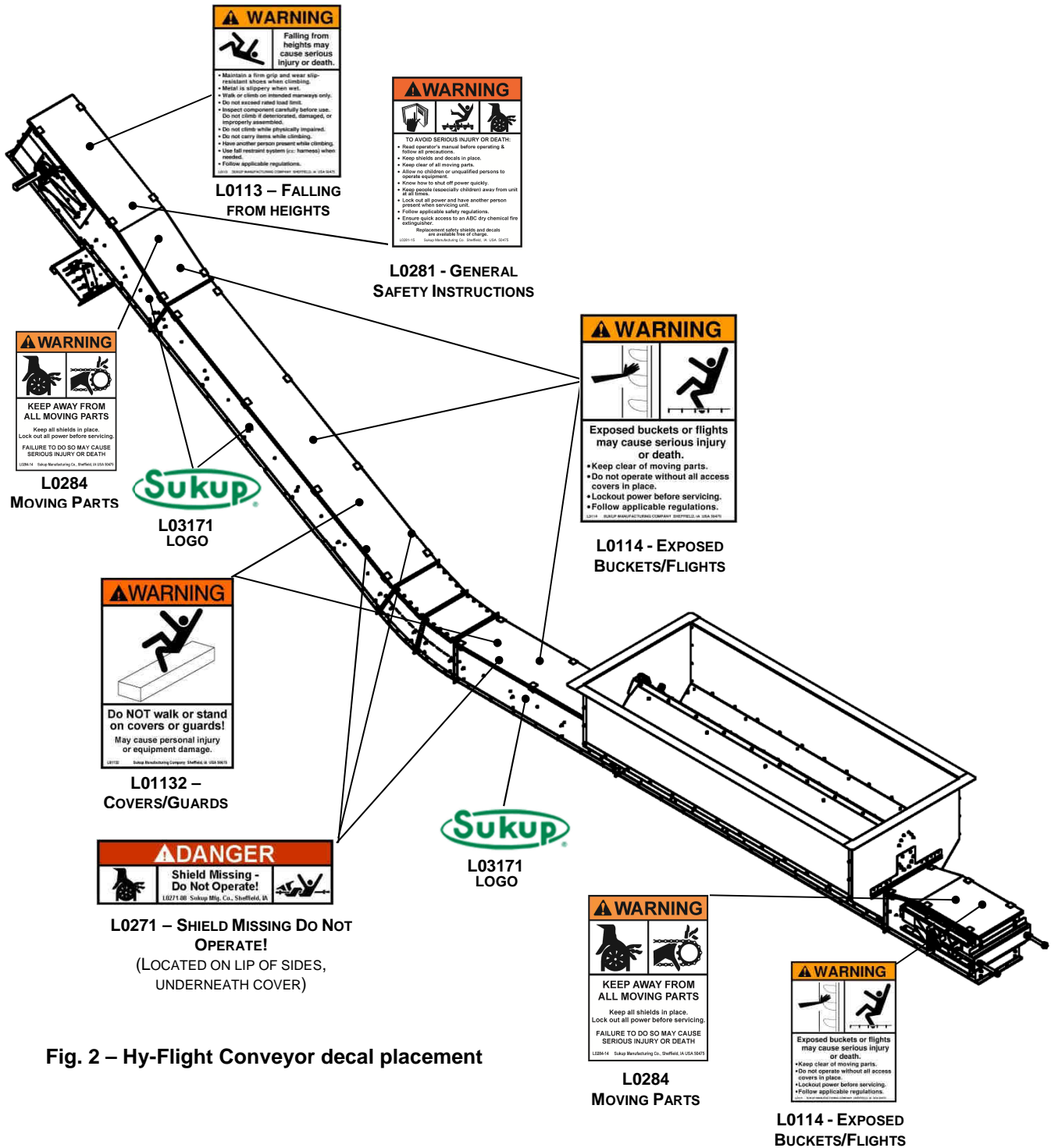

Fig. 2 – Hy-Flight Conveyor decal placement

Hy-Flight Conveyor Final Check and Operation

Final Check

Before operating conveyor, check all areas for SAFETY and machine damage that could have happened during construction. Follow step-by-step procedure below for initial start-up and operation, paying close attention to caution statements.

1. Disconnect and LOCK OUT all electrical power.
2. Check entire conveyor for loose bolts, construction tools, construction debris and/or any other material not related to conveying material, and remove before start-up.
3. Check for proper chain and paddle direction. Check chain tension and adjust if necessary.
4. Check to see that all appropriate decals are present on conveyor.
5. Check to make sure conveyor has been properly aligned.
6. Check all setscrews in drive pulleys, head and tail sprockets, shaft bearings and gear reducer.
7. Check lubrication of gear reducer. **NOTE:** Reducer is shipped without oil. See Pages 60-62.
8. Operate conveyor empty for a period of time, keeping personnel away from moving parts.
9. Disconnect and lock out all electrical power.
10. Make any needed adjustments.
11. Check all discharge gates to ensure they open and close properly.
12. Make sure all covers and guards are re-installed following any adjustments.

Conveyor Operation

Since conveyor has been previously operated without material, it may now be tested under load. It is suggested that flow systems be checked next. Allow only a small amount of grain to enter conveyor. Check that material can flow through system connections, valves, distributors, etc. Once all flow paths have been checked, conveyor may be loaded to capacity.

NOTICE: If conveyor is used for bin unloading, sumps must be control-fed using rack & pinion opener. Over-filling conveyor via sumps can cause damage to conveyor paddles, chains and other components.

INSPECT CONVEYOR AFTER FIRST 8 TO 10 HOURS OF OPERATION. This should include:

- Inspect motor drive for loose pulleys, sprockets, belts, chains, paddles, etc.
- Check for oil leakage or overheating of gear reducer.
- Check head and tail sprocket hub bolts and setscrews.
- Check chain for tension.